

## **STEARNS POWERFUL ELECTROMAGNETIC SUSPENDED SEPARATION MAGNETS**

**...provide the BIG PULL for fast moving burdens**



Stearns compact **4-Pulley Over-The-Belt Magnet** with Armor-Clad Flex-Tuff Belt option.

1. Offers **PROTECTION** for crushers, pulverizers, conveyor belts, screens and other processing equipment by removing tramp iron.
2. Provides **PURIFICATION** of coal, foundry sand, glass cullet, aggregate, grain, food products, chemicals and other products/ingredients for high quality end product by removing tramp iron in process.
3. Provides **RECLAMATION** of ferrous from non-ferrous materials in open hearth and blast furnace, slag, incinerator and garbage plant products, etc.

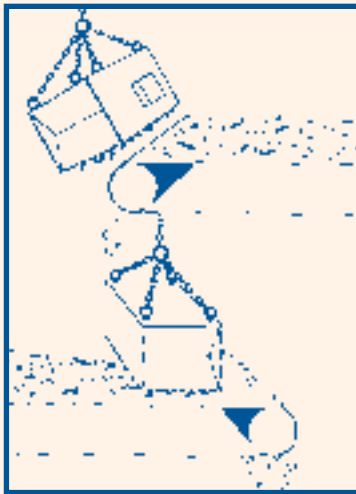

### **STANDARD OVER-THE-BELT MAGNET**

Unwanted tramp iron is easily removed – when the magnet is suspended in the "in-line" or "cross-belt" position.

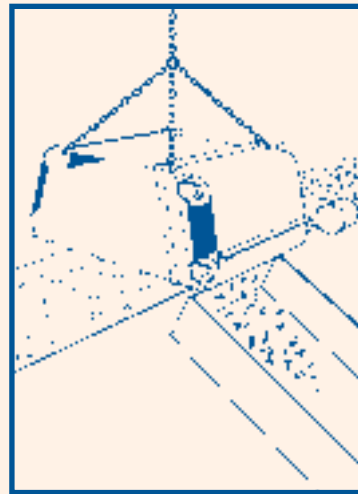

### **CROSS-BELT SELF-CLEANING MAGNET**

Unwanted tramp iron is automatically discharged to either side – when the magnet is positioned at a right angle or "across" the direction of main product conveyor belt travel.

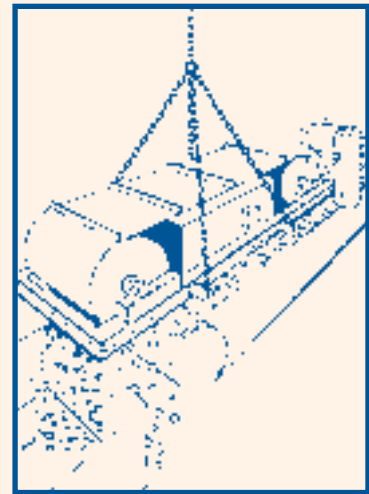

### **IN-LINE SELF-CLEANING MAGNET**

Unwanted tramp iron is automatically discharged to the front – when the magnet is positioned to or "in-line" with the direction of the main product conveyor belt travel.

**RECTANGULAR ELECTRO SUSPENDED MAGNET  
IN-LINE POSITION**

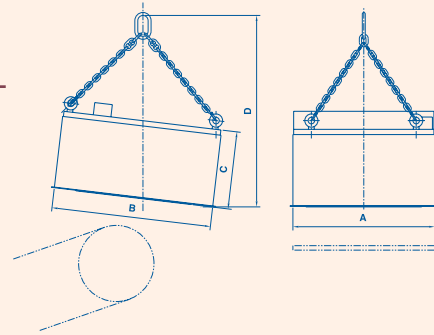

NOTE:SUSPENSION HEIGHT TO BE DEFINED ON  
CUSTOMER APPROVAL DRAWING

**TECHNICAL SPECIFICATIONS**

MODEL	DIMENSIONS (INCHES)				STANDARD VOLTS DC	APPROX. WATTS	APPROX. WT. (lbs.)
	A	B	C	D			
25A	25	34	22-1/8	45	115	2,320	2,000
30A	30	34	23-3/8	47-1/2	115	2,750	2,560
36A	36	38	18-9/16	50-3/4	115	4,290	2,600
38A	38	43	25-7/16	55-1/2	115	4,120	4,430
43A	43	48	26-5/16	60	115	5,060	5,680
48/54M	48	54	26	64-1/4	115	6,200	6,500
48A	48	54	28-1/16	65-3/4	115	6,200	7,740
54A	54	60	29-1/2	71-1/2	230	7,560	10,580
61A	61	68	30-3/4	77-1/4	230	9,260	13,930
68A	68	77	32-3/4	85	230	11,200	19,000
72A	72	78	47	105	230	13,900	26,000
80A	80	86	41-1/4	103	230	15,930	29,000
90A	90	90	45	104	230	20,000	37,000
100A	100	110	49-3/4	107	230	23,400	48,500

OTHER MODELS AVAILABLE PER CUSTOMER REQUEST

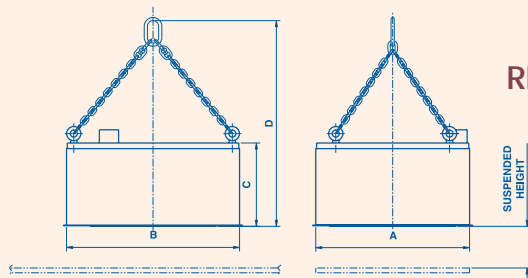

**RECTANGULAR ELECTRO SUSPENDED MAGNET  
CROSS-BELT POSITION**

NOTE:SUSPENSION HEIGHT TO BE DEFINED ON  
CUSTOMER APPROVAL DRAWING

**TECHNICAL SPECIFICATIONS**

MODEL	DIMENSIONS (INCHES)				STANDARD VOLTS DC	APPROX. WATTS	APPROX. WT. (lbs.)
	A	B	C	D			
25A	25	34	22-1/8	45	115	2,320	2,000
30A	30	34	23-3/8	47-1/2	115	2,750	2,560
36A	36	38	18-9/16	50-3/4	115	4,290	2,600
38A	38	43	25-7/16	55-1/2	115	4,120	4,430
43A	43	48	26-5/16	60	115	5,060	5,680
48/54M	48	54	26	64-1/4	115	6,200	6,100
48A	48	54	28-1/16	65-3/4	115	6,200	7,740
54A	54	60	29-1/2	71-1/2	230	7,560	10,580
61A	61	68	30-3/4	77-1/4	230	9,260	13,930
68A	68	77	32-3/4	85	230	11,200	19,000
72A	72	78	47	105	230	13,900	26,000
80A	80	86	41-1/4	103	230	15,930	29,000
90A	90	90	45	104	230	20,000	37,000
100A	100	110	49-3/4	107	230	23,400	48,500

OTHER MODELS AVAILABLE PER CUSTOMER REQUEST



## **STEARNS POWERFUL OVER-THE-BELT MAGNETS MEET YOUR FERROUS REMOVAL DEMANDS**

These heavy duty electro-magnets meet the challenge for reliable tramp iron removal. Strong, deep field magnet designs remove large pieces of ferrous metals from fast moving conveyors dependably with little or no maintenance. Optimum cross section coil construction and efficient oil cooling design provide a broad deep magnetic field and long magnet life. Stearns **Over-The-Belt** Electro-Magnets withstand the most rugged and toughest ferrous metal removal applications such as extreme heat, outdoor and high dust environments.

### **4 PULLEY SPACE SAVING, SELF CLEANING MAGNETS**

Stearns 4 Pulley design includes a rubber tramp iron discharge belt complete with stainless steel cleats that easily carry away large tramp metal from fast moving conveyors. Its very compact design and heavy channel-beam frame construction make this a versatile electro-magnet for many over-the-belt applications. It provides you with:

- **Very Low Maintenance with its Self-Cleaning Design**
- **Its Compact Design Fits Easily into Most Applications**
- **Choice of Oil Cooled or Air Cooled Models**



### **Standard Features**

- **High Strength, Concentrated Deep Magnetic Field**
- **Rugged 100% Duty-Cycle Design**
- **Operates in Hazardous Environments**
- **Heavy Duty Welded Steel Construction**
- **Low Maintenance and Operating Costs**
- **Used in Cross-Belt, In-Line or Chain Hung Applications**
- **Air Cooled Models for Most Applications**

### **Optional Features**

- **Zero Speed Switches**
- **Belt Alignment Switches**
- **Stearns DC Power Supplies**
- **Permanent Magnet Extension**
- **Undercurrent Relay**
- **Fire Resistant Coolants for Hazardous Applications**
- **Explosion Proof Outlet Boxes**
- **Explosion Proof Motors**
- **Custom Painting**
- **Armor-Clad Belt**
- **Direct Drive**
- **Dust Housing**

**4 PULLEY ELECTRO-MAGNETIC  
IN-LINE SEPARATOR**

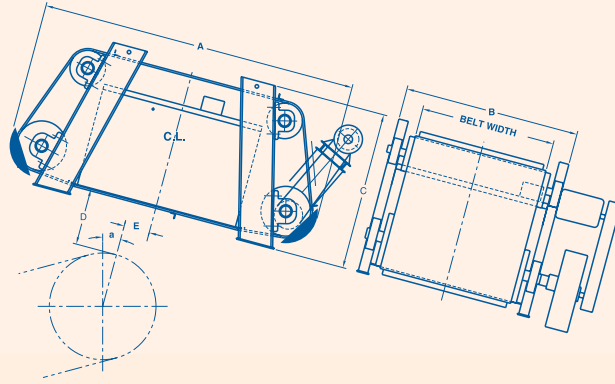

**TECHNICAL SPECIFICATIONS**

MODEL	DIMENSIONS (INCHES)			STANDARD VOLTS DC	APPROX. WATTS	BELT WIDTH (in.)	DRIVE H.P.	APPROX. WT. (lbs.)
	A	B	C					
25A	72	30-1/4	37-1/8	115	2,320	20	1-1/2	2,710
30A	82-1/2	35-1/2	38-3/8	115	2,752	24	2	3,330
36A	78-3/8	41-1/2	38-3/8	115	4,290	30	3	4,500
38A	82-1/2	43-1/4	40-1/2	115	4,120	30	3	5,410
43A	89	48-1/2	41-3/8	115	5,060	36	3	6,760
48/54M	97	53-1/2	41-1/8	115	6,200	42	3	8,700
48A	97	53-1/2	43-1/8	115	6,200	42	3	8,990
54A	103-1/4	59-1/2	44-1/2	230	7,560	48	5	12,160
61A	111	66-3/4	45-3/4	230	9,260	54	5	15,660
68A	120-3/8	73-3/4	47-3/4	230	11,200	60	7-1/2	20,880
72A	120-3/4	78	57	230	13,900	66	10	28,500

DIMENSIONS "D", "E" & ANGLE  $\alpha$  WILL BE DEFINED ON CUSTOMER APPROVAL DRAWING

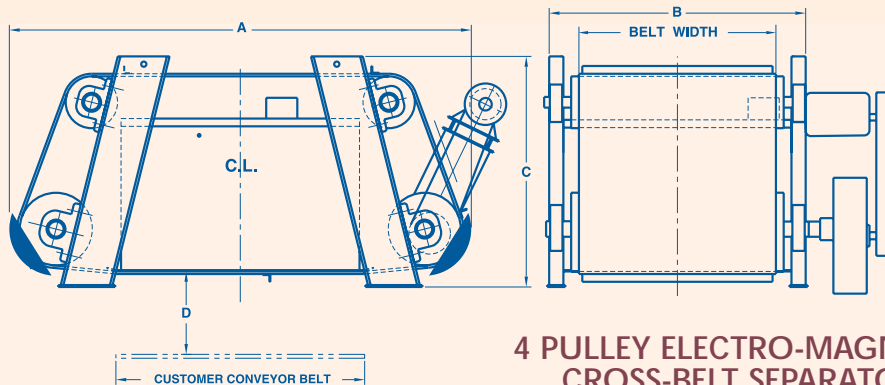

**4 PULLEY ELECTRO-MAGNETIC  
CROSS-BELT SEPARATOR**

**TECHNICAL SPECIFICATIONS**

MODEL	DIMENSIONS (INCHES)			STANDARD VOLTS DC	APPROX. WATTS	BELT WIDTH (in.)	DRIVE H.P.	APPROX. WT. (lbs.)
	A	B	C					
25A	63	39-1/4	37-1/8	115	2,320	30	2	2,860
30A	68	39-1/4	38-3/8	115	2,752	30	2	3,430
36A	76-3/8	43-1/2	38-3/8	115	4,290	32	3	4,600
38A	78	48-1/2	40-1/2	115	4,120	36	3	5,500
43A	84-1/2	53-1/2	41-3/8	115	5,060	42	3	6,900
48/54M	91	59-1/2	41-1/8	115	6,200	48	5	8,900
48A	91	59-1/2	43-1/8	115	6,200	48	5	9,170
54A	96	65-1/2	44-1/2	230	7,560	54	5	12,270
61A	103-3/4	73-3/4	45-3/4	230	9,260	60	5	15,770
68A	111-3/8	82-3/4	47-3/4	230	11,200	70	7-1/2	21,310
72A	128	84	57	230	13,900	72	10	28,500

DIMENSION "D" WILL BE DEFINED ON CUSTOMER APPROVAL DRAWING



## 2 PULLEY ELECTRO-MAGNET IN-LINE SEPARATOR

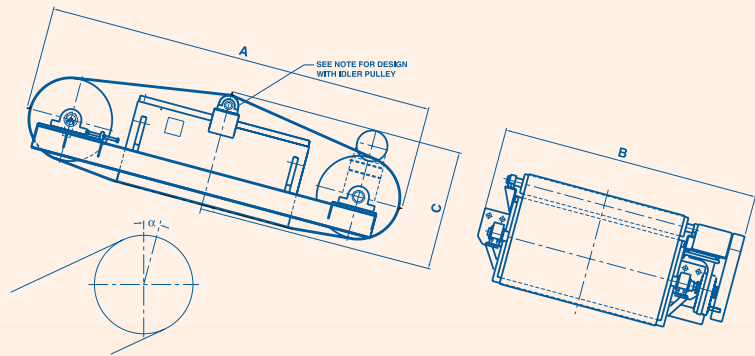

### TECHNICAL SPECIFICATIONS

MODEL	DIMENSIONS (INCHES)			VOLTS DC	WATTS DC	BELT WIDTH (in.)	DRIVE H.P.	APPROX. WT. (lbs.)
	A	B	C					
25A	89-1/2	50	31-1/2	115	2,320	20	1-1/2	3,200
30A	95	56	31-1/2	115	2,752	24	2	4,000
36A	94	57-3/4	25-3/4	115	4,290	30	3	4,200
38A	114	65	34-1/2	115	4,120	30	3	5,500
43A	120	68	36	115	5,060	36	3	8,400
48/54M	126	79	36	115	6,200	42	3	9,800
48A	126	79	38	115	6,200	42	5	10,000
54A	148	85	39-1/2	230	7,560	48	5	12,800
61A	145	92	36	230	9,260	54	5	16,000
68A	165	101	39-1/2	230	11,200	60	7-1/2	23,000
*72A	190	112	62	230	14,000	66	10	32,000
*80A	198	120	56	230	15,900	72	10	38,000
*90A	200	135	59	230	20,000	82	20	48,200

1) MODELS WITH \* ARE THREE (3) PULLEY DESIGN • 2) ANGLE  $\alpha$  IS DEFINED ON CUSTOMER APPROVAL DRAWING

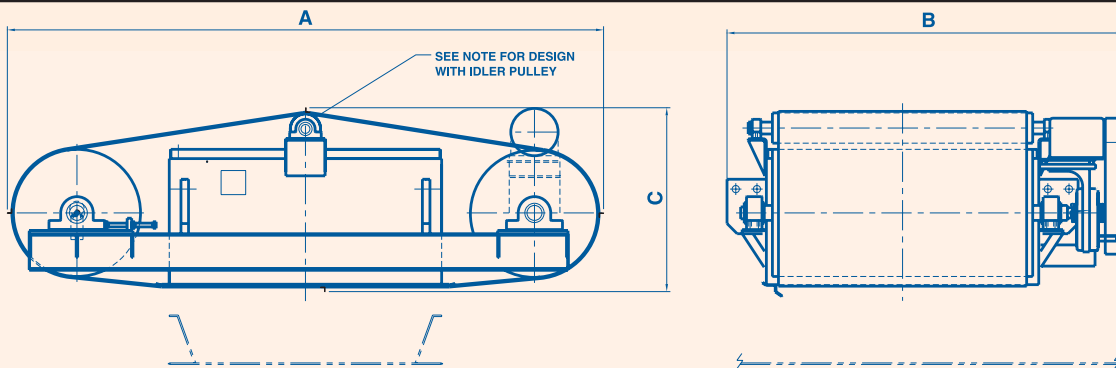

## 2 PULLEY ELECTRO-MAGNET CROSS-BELT SEPARATOR

### TECHNICAL SPECIFICATIONS

MODEL	DIMENSIONS (INCHES)			VOLTS DC	WATTS DC	BELT WIDTH (in.)	DRIVE H.P.	APPROX. WT. (lbs.)
	A	B	C					
25A	86-1/2	58-1/4	31-1/2	115	2,320	30	2	3,100
30A	91	59-1/2	31-1/2	115	2,752	30	2	3,900
36A	92	63-1/2	25-3/4	115	4,290	32	3	4,100
38A	109	70	34-1/2	115	4,120	36	3	5,400
43A	115	73	36	115	5,060	42	3	8,300
48/54M	120	85	36	115	6,200	42	3	9,700
48A	120	85	38	115	6,200	48	5	9,900
54A	142	91-1/2	39-1/2	230	7,560	54	5	12,700
61A	138	98	36	230	9,260	60	5	15,850
68A	156	110	39-1/2	230	11,200	70	7-1/2	22,800
*72A	184	118	62	230	14,000	72	10	31,800
*80A	192	126	56	230	15,900	78	10	37,800
*90A	200	135	59	230	20,000	82	20	48,200

1) MODELS WITH \* ARE THREE (3) PULLEY DESIGN