

OHIO MODEL RD-2A AUTO/MANUAL DROP MAGNET CONTROLLER

INSTALLATION, MAINTENANCE, AND PARTS BULLETIN
OPERATING RANGE 100-150 A (COLD MAGNET CURRENT)

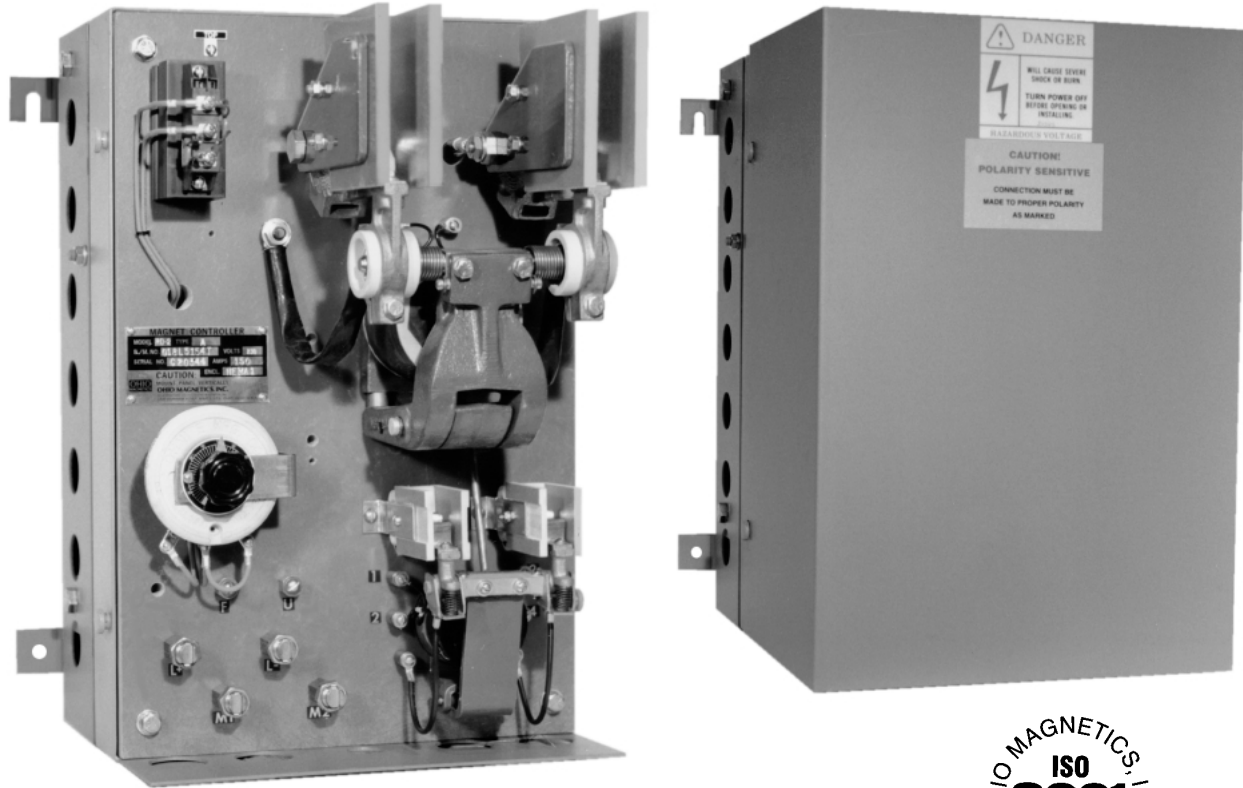

DESCRIPTION

The RD-2A Controller is a heavy duty magnet controller used for magnets whose cold current ranges from 100 A to 150 A dc. Cold current references the current flowing through the magnet when the magnet temperature is 25°C throughout.

AUTOMATIC DROP

A reverse current adjustment provides for a fast, clean drop

of the magnet over a complete range of magnetic material with one movement of the master switch or push button.

MANUAL DROP

Allows for partial dropping of the load by controlling the amount of reverse current to the magnet. A drop position on the master switch or a push button that is spring returned to off, gives the operator complete control of the drop cycle.

INSTALLATION PROCEDURES

- Mount the controller to a solid surface with the mounting bars provided.
- The controller must be mounted vertically with the "TOP" up to operate properly.
- Mount the controller away from sources of heat and direct exhaust of engines.
- Allow enough room around the controller for air circulation.
- Route electrical wires through bottom of the enclosure and connect securely to the terminals.
- All electrical circuits must be free from grounds and shorts.
- Remove shipping material from the arc shields before operating the controller.

- Adjust the reverse current control rheostat to provide enough reverse current to cleanly drop the magnet load.

Procedure Start with the dial set at low range. Pick up and drop a load of the material to be handled. If the material does not completely fall off the magnet, increase the adjustment and try another load. If the material drops off and then some jumps back up to the magnet before it can fall free, reduce the adjustment and try another load. When all the material falls cleanly from the magnet, the controller is properly set.

RD-2A SUBASSEMBLIES

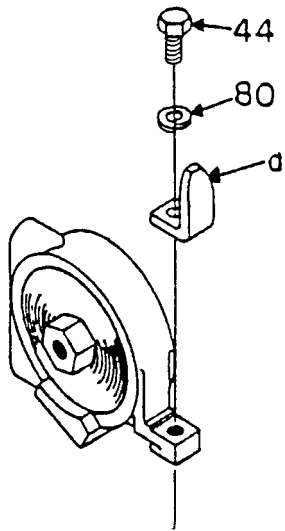

018B0217A 27

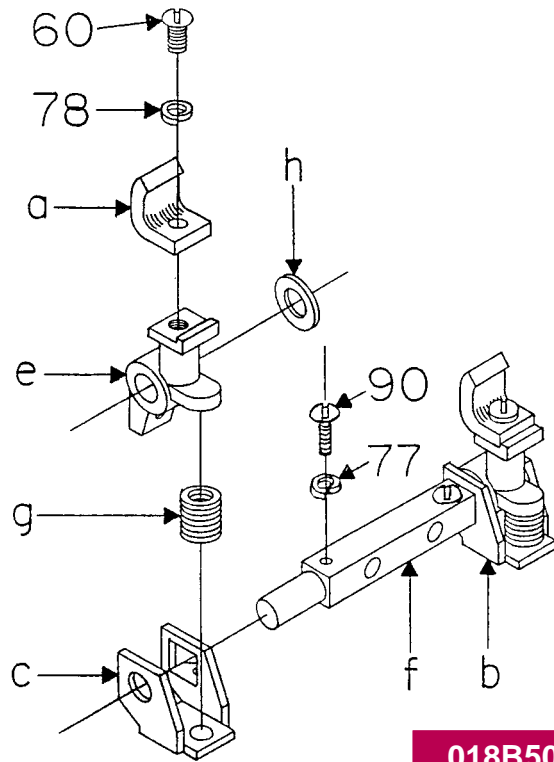

018B5074X 31

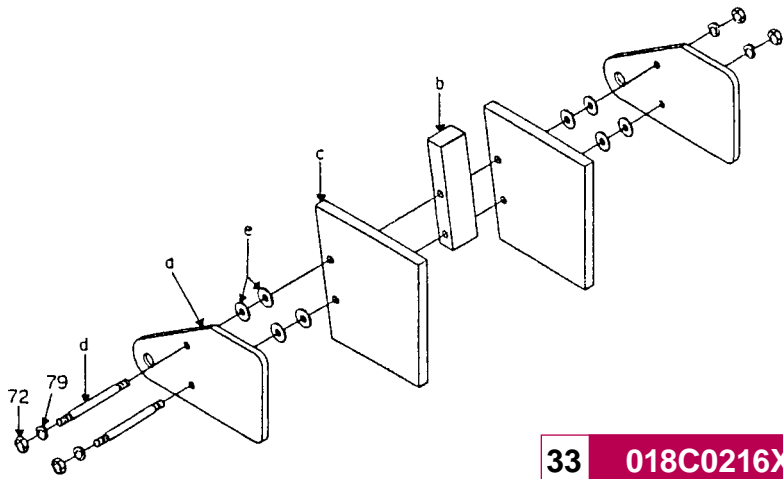

33 018C0216X

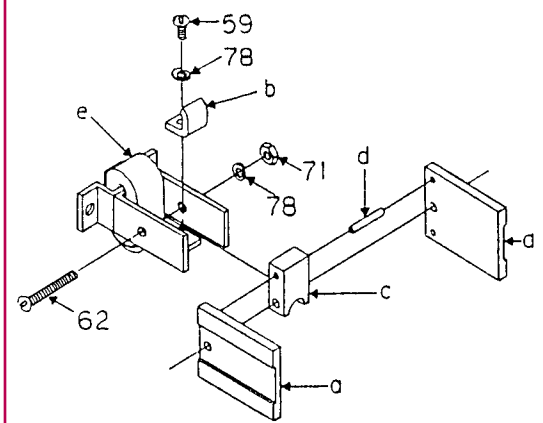

28 018B1478X

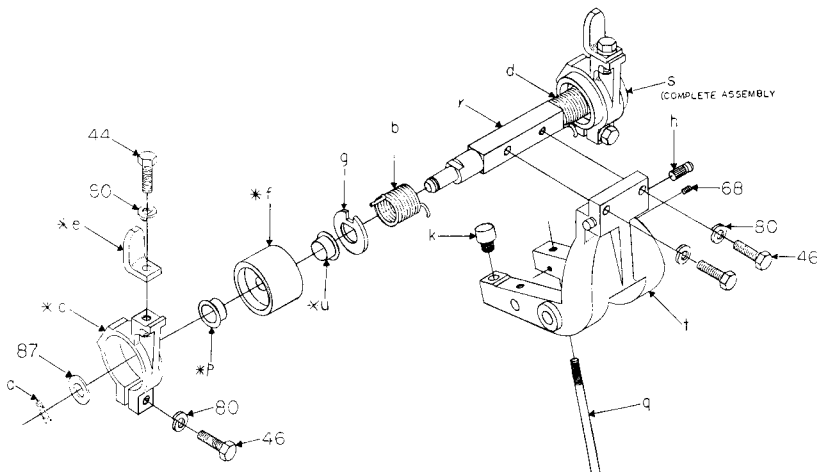

018D3090B 35

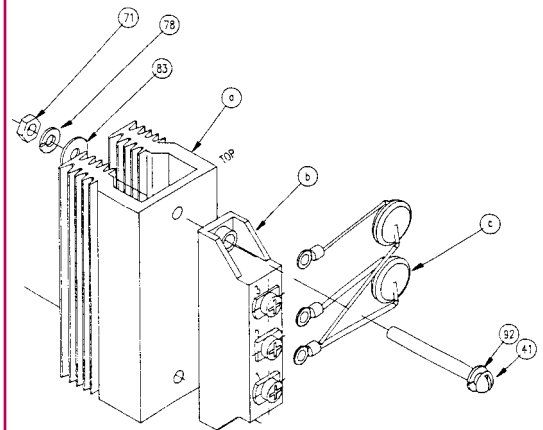

29 018B2966V

OHIO MODEL RD-2A AUTO/MANUAL DROP MAGNET CONTROLLER

RD-2A CONTROLLER EXPLODED ASSEMBLY VIEW

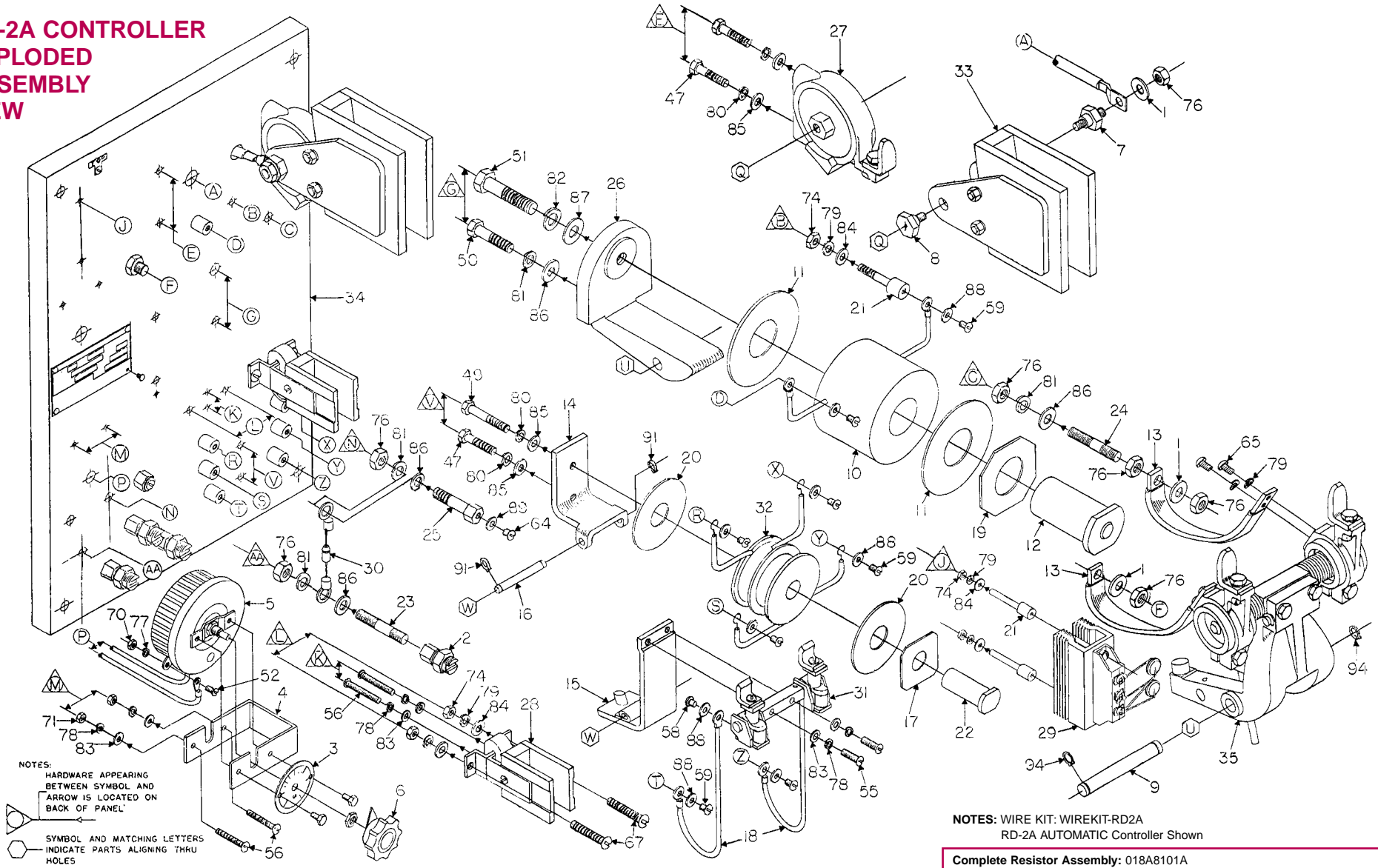

NOTES:
HARDWARE APPEARING
BETWEEN SYMBOL AND
ARROW IS LOCATED ON
BACK OF PANEL

SYMBOL AND MATCHING LETTERS
INDICATE PARTS ALIGNING THRU
HOLES

NOTES: WIRE KIT: WIREKIT-RD2A
RD-2A AUTOMATIC Controller Shown

Complete Resistor Assembly: 018A8101A

NOT SHOWN	018A8101G	7 Req'd	Resistor—3.2 Ohms
	018A8101E	2 Req'd	Connector
	018A8101F	5 Req'd	Terminals
	018A8101D	3 Req'd	Connector
	018A8101C	28 Req'd	Mica Washers

RD-2A HARDWARE SPECIFICATIONS LIST

ITEM	PART NUMBER	QTY.	DESCRIPTION	MAT'L
44	A-900007-02	4	SCR HX HD 5/16-18 UNC x 3/4"	STEEL
46	A-900007-05	4	SCR HX HD 5/16-18 UNC x 1-1/4"	STEEL
47	A-900007-06	5	SCR HX HD 5/16-18 UNC x 1-1/2"	STEEL
49	A-900007-08	1	SCR HX HD 5/16-18 UNC x 2"	STEEL
50	A-900008-08	1	SCR HX HD 3/8-16 UNC x 1-3/4"	STEEL
51	A-900010-09	1	SCR HX HD 1/2-13 UNC x 2-1/2"	STEEL
52	A-900416-05	3	SCR RH SLTD M4 x 0.7 x 10 mm	STEEL
55	A-900023-07	2	SCR RH SLTD #10-32 UNF x 7/8"	STEEL
56	A-900023-09	7	SCR RH SLTD #10-32 UNF x 1-1/4"	STEEL
59	A-900023-14	10	SCR RH SLTD #10-32 UNF x 3/8"	BRASS
60	A-900023-15	2	SCR RH SLTD #10-32 UNF x 1/2"	BRASS
62	A-900023-25	2	SCR RH SLTD #10-32 UNF x 1-3/4"	BRASS
63	A-900023-28	1	SCR RH SLTD #10-32 UNF x 1-3/8"	STEEL
64	A-900025-16	2	SCR RH SLTD 1/4-20 UNC x 3/8"	BRASS
65	A-900025-17	4	SCR RH SLTD 1/4-20 UNC x 1/2"	BRASS
67	A-900025-22	4	SCR RH SLTD 1/4-20 UNC x 1-3/4"	BRASS
68	A-900061-02	1	SCR SET HX SOC CP PT #10-32 x 1/4"	STEEL
70	A-900106-38	3	NUT HX M4 x 0.7 mm	STEEL
71	A-900106-03	5	NUT HX #10-32 UNF	STEEL
72	A-900106-05	8	NUT HX 1/4-20 UNC	STEEL
74	A-900108-11	2	NUT HX JAM 1/4-20 UNC	BRASS
75	A-900108-12	4	NUT HX JAM 5/16-18 UNC	BRASS
76	A-900172-07	20	NUT HX JAM 3/8-16 UNC	BRASS
77	A-900115-28	5	M4 SPLIT LOCKWASHER	STEEL
78	A-900115-03	25	#10 SPLIT LOCKWASHER	STEEL
79	A-900115-05	22	1/4" SPLIT LOCKWASHER	STEEL
80	A-900115-06	19	5/16" SPLIT LOCKWASHER	STEEL
81	A-900115-07	10	3/8" SPLIT LOCKWASHER	STEEL
82	A-900115-09	1	1/2" SPLIT LOCKWASHER	STEEL
83	A-900118-03	11	#10 FLATWASHER	STEEL
84	A-900118-05	14	1/4" FLATWASHER	STEEL
85	A-900118-06	8	5/16" FLATWASHER	STEEL
86	A-900118-07	10	3/8" FLATWASHER	STEEL
87	A-900118-09	3	1/2" FLATWASHER	STEEL
88	A-900118-18	10	#10 FLATWASHER	BRASS
89	A-900118-20	2	1/4" FLATWASHER	BRASS
90	A-900021-23	2	SCR RD SLTD #8-32 UNF x 3/4"	BRASS
91	A-900219-02	2	EXT. RET. RING—1/4" SHAFT	STEEL
94	A-900219-09	2	EXT. RET. RING—1/2" SHAFT	STEEL
96	A-900118-21	4	3/8" FLATWASHER	BRASS
97	A-900023-12	2	SCR RD SLTD #10-32 UNF x 1/4"	BRASS
98	A-900118-27	2	#10 FLATWASHER	BRASS
99	A-900115-18	2	#10 SPLIT LOCKWASHER	BRASS

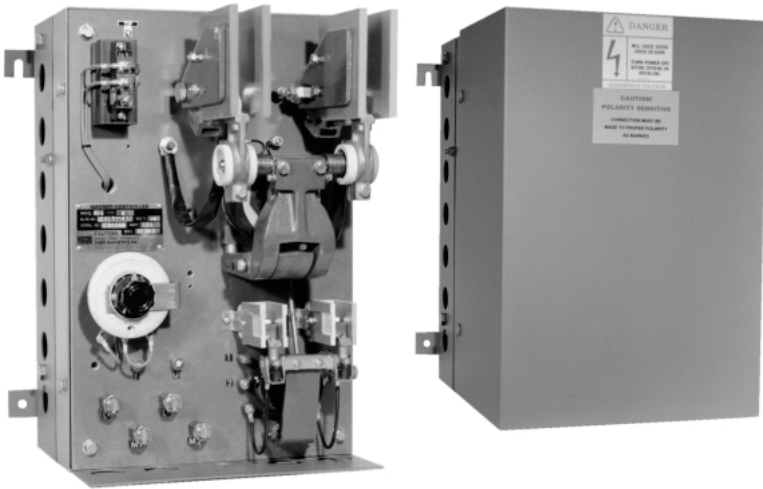

ITEM	PART NUMBER	REQ.	DESCRIPTION
			Man/Auto
1	A-900118-21	4	3/8" FLATWASHER
2	A-900215-02	4	CABLE CONNECTOR (#2-#8)
3	A-900228-01A	0/1	RHEOSTAT DIAL
4	A-900229-02	0/1	RHEOSTAT MNTG. KIT.
5	A-900232-04	0/1	RHEOSTAT—0.5 Ω-150 W
6	A-900233-02	0/1	RHEOSTAT KNOB
7	018A0123X	2	BLOWOUT BLT.—W/STUD
8	018A0124X	2	BLOWOUT BLT.
9	018A0140C	1	ARM PIN—1/2" DIA. (Ø12 mm)
10	018A0151F	1	MAIN COIL—230 V
11	018A0152X	2	INSULATING WASHER
12	018A0154A	1	CORE ASSEMBLY
13	018A0317D	2	SHUNT ASSEMBLY
14	018A2615X	1	SWITCH FRAME
15	018A2622X	1	SWITCH ARM ASSEMBLY
16	018A2623A	1	ARM PIN—1/4" DIA. (Ø6 mm)
17	018A2637X	1	SPRING WASHER
18	018A2720X	2	SHUNT ASSEMBLY
19	018A2866X	1	CLAMP WASHER
20	018A2977X	2	SEPARATOR WASHER
21	018A3010X	8/10	TERMINAL STUD
22	018A3075X	0/1	REVERSE SWITCH CORE
22a	018A6209A	1/0	REVERSE CORE ASSEMBLY
23	018A3878A	4	TERMINAL STUD—2-1/2" (65 mm)
24	018A3878X	2	TERMINAL STUD—2-3/4" (70 mm)
25	018A3882X	3/2	TERMINAL STUD
26	018B0116X	1	MAIN FRAME
27	018B0217A	2	BLOWOUT COIL ASSEMBLY
27a	018A0125X	2	CONTACT TIP
28	018B1478X	2	BLOWOUT COIL ASSEMBLY
28a	018A0803X	4	ARC SHIELD SIDE
28b	018A1443X	2	CONTACT TIP
28c	018A1503X	2	ARC SHIELD SPACER
28d	018A1523X	2	DOWEL
28e	018B2727X	2	BLOWOUT COIL ASSEMBLY
29	018B2966V	1	DIODE ASSEMBLY
29a	A-900565-18	1	HEAT SINK—DRILLED
29b	A-900550-26	1	DIODE MODULE
29c	018A2966Q	2	MOV SUPPRESSOR ASSEMBLY
30	018A2966Z	1	CONTROL DIODE
31	018B5074X	1	SWITCH ARM ASSEMBLY
31a	018A1443X	2	CONTACT TIP
31b	018A2604A	1	CONTACT BRACKET
31c	018A2605A	1	CONTACT BRACKET
31d	018A2614A	2	CONTACT ARM ASSEMBLY
31e	018A2614X	2	CONTACT ARM
31f	018A2618X	1	REVERSE ARM SHAFT
31g	018A2625X	2	CONTACT SPRING
31h	018A2631X	2	SPACER WASHER
32	018A1508A	1/0	REVERSE SWITCH COIL 36 V
32a	018B6156X	0/1	DROP COIL
33	018C0216X	2	ARC SHIELD ASSEMBLY
33a	018A0120X	4	BLOWOUT EAR
33b	018A0126X	2	SPACER
33c	018A0130X	4	BLOWOUT SHIELD
33d	018A0139X	4	STUD—3-1/8" (80 mm)
33e	018A1362X	16	WASHER
34	018C5184X	1	PANEL
35	018D3090B	1	MAIN ARM ASSEMBLY
35a	A-900221-05	2	HAIR PIN CLIP—Ø3/8" (Ø10 mm) SHAFT
35b	018A0104X	1	SPRING—LEFT
35c	018A0118X	2	CONTACT ARM—MACHINED
35d	018A0121X	1	SPRING—RIGHT
35e	018A0125X	2	CONTACT TIP
35f	018A0128A	2	ARM INSULATION
35g	018A0129X	2	STOP WASHER
35h	018A0135X	2	SPRING PIN
35k	018A0138X	1	STOP
35p	A-900298-02	2	BEARING—SELF LUBRICATING
35q	018A5645X	1	THREADED ROD
35s	018B0219A	2	CONTACT ARM ASSEMBLY
35t	018C2992A	1	MAIN ARM—MACH.
35u	A-900298-03	2	BEARING—SELF LUBRICATING

RD-2A WIRING DIAGRAM

RD-2A AUTOMATIC CONTROLLER

WIRE DIAGRAM P/N: 018B6155V

RD-2A MANUAL CONTROLLER

WIRE DIAGRAM P/N: 018B6155AA

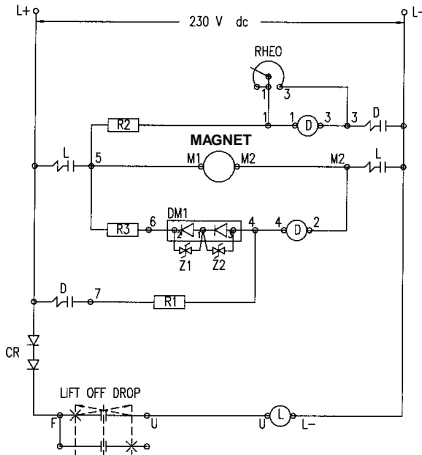

SCHEMATIC DIAGRAM

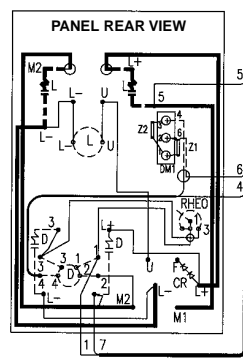
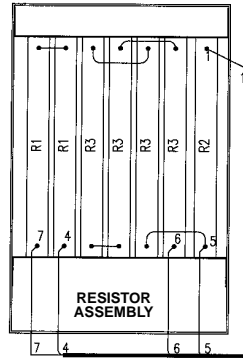

WIRING DIAGRAM

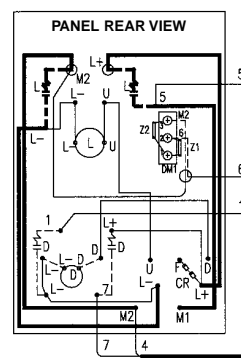
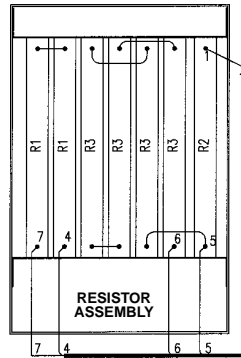

WIRING DIAGRAM

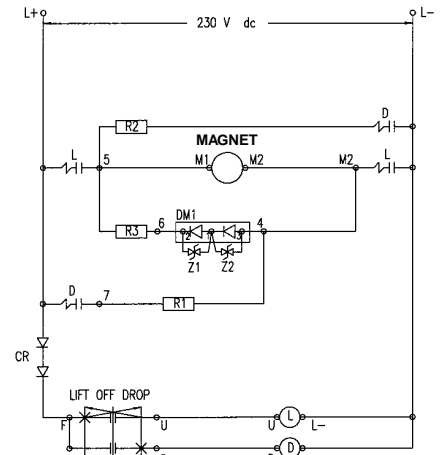

SCHEMATIC DIAGRAM

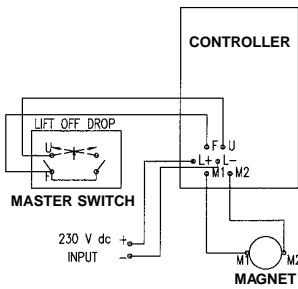

SYSTEMS DIAGRAM

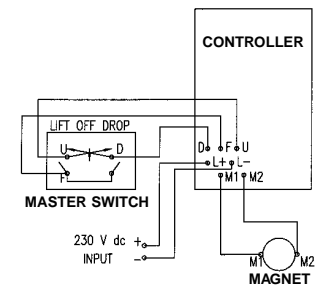

SYSTEMS DIAGRAM

TABLE OF EQUIPMENT

SYMBOL	DESCRIPTION	FUNCTION
D	REVERSE CONTACTOR	DROP
L	MAIN CONTACTOR	LIFT
R1	3.2 Ω RESISTORS	DROP RESISTOR
R2	3.2 Ω RESISTORS	DROP RESISTOR
R3	3.2 Ω RESISTORS	DISCHARGE RESISTOR
RHEO.	0.5 Ω RHEOSTAT	DROP ADJUSTMENT
DM1	DIODE	BLOCKING DIODE
Z1-Z2	MOV SUPPRESSOR	DIODE PROTECTION
CR	CONTROL RECTIFIER	ANTI-REVERSE PROTECTION

STEP BY STEP CONTROLLER OPERATION

AUTOMATIC CONTROLLER

1. When a lift signal is given by closing the contacts between terminals "F" and "U", the "L" coil is energized.
2. This closes the "L" contacts which supplies full power to the magnet.
3. When a drop signal is given the "F" to "U" contact is broken and the "L" coil is de-energized.
4. This opens the "L" contacts and at the same time allowing current to flow through blocking diode DM1.
5. A discharge circuit is set up through resistors "R3" and the "4", "2" winding of the "D" coil, (energizing the coil).

6. This causes the energy in the magnet to be dissipated to the "R3" resistor, and the "D" contacts to close.
7. Reverse voltage is then applied to the magnet through the "R1" and "R2" resistors.
8. When the proper amount of reverse current to the magnet, (as adjusted by the rheostat), is measured by the "4", "2" winding of the "D" coil, it cancels the affect of the "1", "3" winding of the "D" coil and the "D" contacts open.
9. This stops the flow of reverse current through the magnet.

STEP BY STEP CONTROLLER OPERATION

MANUAL CONTROLLER

1. When a lift signal is given by closing the contacts between terminals "F" and "U", the "L" coil is energized.
2. This closes the "L" contacts which supplies full power to the magnet.
3. When a drop signal is given the "F" to "U" contact is broken and the "L" coil is de-energized.
4. This opens the "L" contacts and allows current to flow through blocking diode DM1.
5. A discharge circuit is set up through resistor "R3".
6. Energy in the magnet is dissipated to the "R3" resistor.
7. Moving the master switch to the drop position or pushing the drop button, closes the contact between terminals "F" and "D", energizing the "D" coil.
8. This closes the "D" contacts and provides reverse voltage to the magnet, through resistors "R1" and "R2".
9. To stop the build up of reverse current, release the master switch control and it will return to the off position, or release the drop push button.
10. This breaks the contact between the "F" and "D" terminals, de-energizes the "D" coil, (opening the "D" contacts), and stops the flow of reverse current through the magnet.

MAINTENANCE AND TROUBLE SHOOTING

Check all contact tips for excess wear or burning. Replace if needed.

Check arc shields for burnt areas. Replace any that are badly burned.

Check for burned or damaged insulation on shunts or wires. Replace if found.

Check for carbon tracking on the base panel and insulating parts. If found, remove by filing or scraping. If carbon can not be removed, replace the part.

Check gap ($\frac{3}{4}$ " (20 mm) opening) between main contacts (#27a and #35e). Adjust by loosening screw (#46) on part (#35c) and turning the assembly.

All pin connections should move easily, and contact

springs should provide force when contacts are closed. If springs do not provide contact force, replace them.

Check Power Diode Integrity (DM1) with a standard Digital Volt Meter (DVM), set to the diode check function. (See owner's manual for details.) Disconnect leads to the diode and remove suppressors MOV (Z1 and Z2) to isolate from the circuit. Place the red lead of meter on Terminal 1 of diode (number is stamped next to terminal) and the black lead on Terminal 2. Meter should read <1.0. Reverse leads and meter should read 1.(00). Repeat for Terminals 3 (red) and 1 (black). If the diode reads bad, replace. Reconnect wires and MOVs (Z1 and Z2).

NOTE: Z1 and Z2 are MOV suppressors to help limit voltage spikes applied to DM1 and causing damage.

EMERGENCY SPARE PARTS KITS AND /OR KITS

Automatic — #ESP-018M5154TI

- Contains the parts most likely to fail due to a system problem or a high voltage spike. It is recommended that one of these kits be kept on hand to avoid unnecessary down time.

Conversion Kit — #018M2966W

- Converts old style contact arm to diode.



OHIO MAGNETICS—PERFORMANCE ENGINEERED



OHIO MAGNETICS, INC. SUBSIDIARY OF PEERLESS-WINSMITH, INC.

5400 DUNHAM ROAD, MAPLE HEIGHTS, OH 44137-3687 • 800/486-6446 • 216/662-8484 • FAX: 216/662-9526 • 216/662-2911 • 216/662-3118
E-mail: salesohiomag1@qwest.net • engohiomag1@qwest.net Sales Company Engineering
Web sites: ohiomagnetics.com • stearnsmagnetics.com

Stearns
magnetics